

MANUAL

R130/R135

Roughness tester



Changes in products and/or product specifications can emerge due to new technologies and continuous development.

We reserve the right to change or modify specifications of products without prior notice.

We recommend you to contact our sales office for up-to-date information.

© All rights reserved

Contents

1.	Description	2
2.	Specification	3
3.	Measurement parameters	4
4.	Features	5
5.	Battery installation/replacement	6
5.1	Controls and digital display	6
6.	Calibration	8
7.	Operation	10
8.	Probes	11
8.1	General purpose probe	11
8.2	Transverse chisel probe	11
8.3	Parallel chisel probe	11
8.4	Small bore probe	12
8.5	Groove bottom probe	12
9.	Probe replacement	13
10.	Analog signals output	14
11.	Maintenance	15
11.1	Protection & storage	15
11.2	Cleaning	15
11.3	Repairs	15
12.	Accessory: height stand	16

1. Description

The R130 tester is a portable, battery-powered instrument for checking surface roughness with the measured values displayed on a digital readout.

The instrument can be used in the laboratory, an inspection area, in the shop, or wherever on-site surface roughness testing is required.

NOTE:

Even though this instrument is designed and built to withstand the rigors of handling and use, it is a precision instrument and should be treated with care to assure measurement accuracy and reliable performance.

R130 standard kit is furnished in a fitted case and includes:

- R130 unit with a general purpose probe (R130-2002)
- reference specimen
- 9-volt alkaline battery
- riser plate for calibrating the gage with the reference specimen
- screwdriver.

2. Specification

- Measuring ranges : Ra-0.03 μ m~6.3 μ m/1 μ "~250 μ "
Rz-0.2 μ m ~18.5 μ m/8 μ "~999 μ "
- Display Resolution: 0.01 μ m /1 μ "
- Cut-off: 0.25mm/0.8mm/2.5mm, ANSI 2RC Filter
- Display: 3-digital LCD
- Measure Accuracy: Meets ISO and DIN standards

Traverse lengths and evaluation lengths:

Cut-off = 0.25mm

Traverse length	Evaluation length	Numbers of cutoff
0.75mm	0.25mm	1
1.25mm	0.75mm	3
1.75mm	1.25mm	5

Cut-off = 0.8mm

Traverse length	Evaluation length	Numbers of cutoff
1.2mm	0.8mm	1
3.0mm	2.4mm	3
4.5mm	4.0mm	5

Cut-off = 2.5mm

Traverse length	Evaluation length	Numbers of cutoff
3.0mm	2.5mm	1

- Probe type : Piezoelectric
- Maximum stylus force: 15.0mN / 1500mgf
- Power: 9-volt consume-type alkaline battery
- Battery capacity: Approx. 3000 measurements
- Operating temperature: 10°~45°C / 50°~113°F
- Storage temperature : 0°~60°C / 32°~147°F

3. Measurement parameters

- Ra

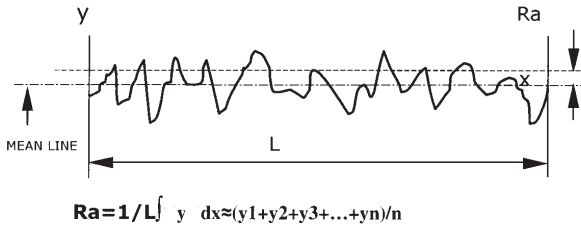

Roughness Average—the arithmetic average height of roughness irregularities measured from a mean line within the evaluation length (L)

- Rz

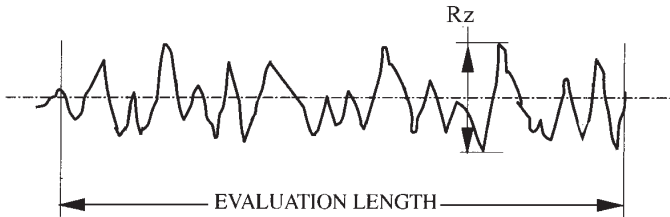

Maximum Roughness Depth —The largest of the peak_to_valley roughness depths in the evaluation length.

4. Features

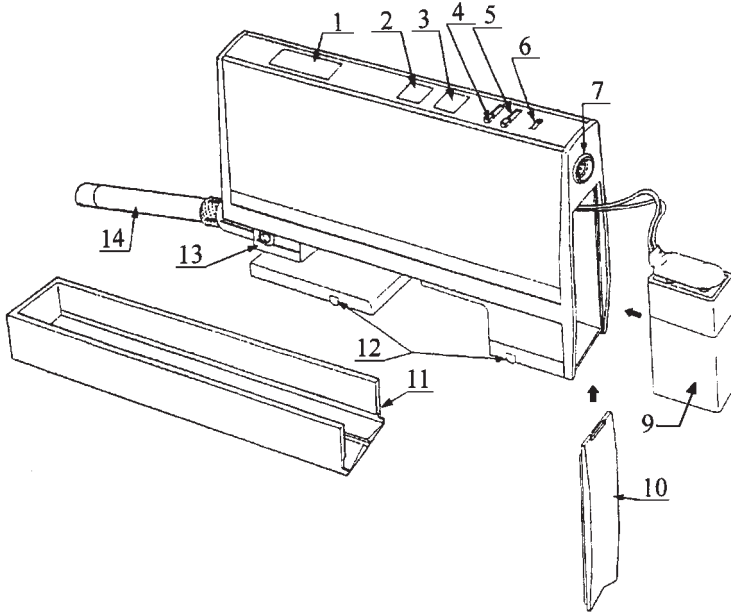

- 1 Digital display
- 2 Start button
- 3 Parameter selection button
- 4 Cut-off selection switch
- 5 Traverse length switch
- 6 Meter/inch switch
- 7 Output connector (accessory)
- 9 Battery (alkaline)
- 10 Battery compartment cover
- 11 Protective cover
- 12 2 "V" feet
- 13 Probe holding block
- 14 Probe

5. Battery installation /replacement

(Alkaline only)

1. Remove protective cover from the gage base and slide battery compartment cover off end of the gage .
2. Install/replace alkaline battery and replace battery compartment cover.
3. Set On/Off, push "START" to check battery condition (see next section)

5.1 Controls and digital display

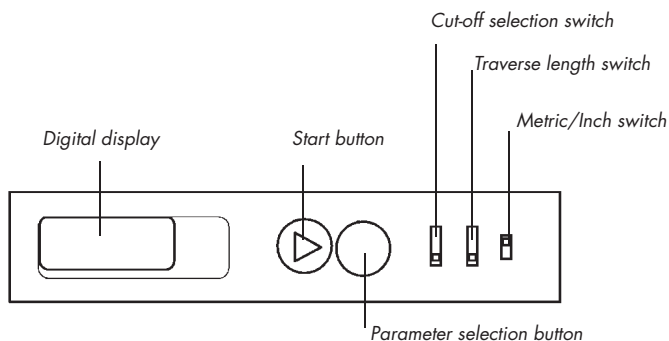

1. Set power switch for "START", it should display "1-000". If it no display or display "8-888", it indicating weak battery, and must remove and replace the battery.
2. Set Metric/Inch switch for metric (μm) or inch (μ''). Set Cut-off selection switch for 0.25mm, 0.8mm, 2.5mm, base on the roughness value be estimated. Refer to Table 1. Set traverse length switch for 1, 3 or 5. Refer to specification section's traverse length for detail.
3. Press and release "start" button, the readout should display "1-X.XX" (R_a). If the readout display "8-888", it indicating a low battery, and need to replace the battery.
4. If the R_a or R_z value displayed is out of the measuring rang which accordance with the selected Cut-off, then re-select the cut-off . Refer to table 1 .
5. The digital readout also can display "2-X.XX" (R_z) in circularly by press and release the parameter selection button.

Table 1:

Measuring ranges (Ra)	Measuring ranges (Rz)	Cut-off (lc)
0.03µm Ra 0.1µm	0.1µm Rz 0.5µm	0.25mm
0.1µm < Ra < 2.0µm	0.5µm < Rz < 10.0µm	0.8mm
2.0µm Ra 6.3µm	10.0µm Rz 50.0µm	2.5mm

The tester can be switch on with the ">" (start) key and be turned off automatically after 2 minutes.

If the tester is auto switched off, the last measuring result can't be shown on the screen when re-start the tester as this auto-off is the real off (power cut-off).

6. Calibration

Prior to operating the tester, its calibration should be checked.

1. The tester is calibrated using the reference specimen. Set cut-off selection switch to position "0.8mm", set the traverse length switch to position "5", and set the metric/inch switch to position "metric". Place the specimen into the groove of the calibration plate, place the tester on the calibration plate. Make sure that the probe stylus was in the middle of the specimen.

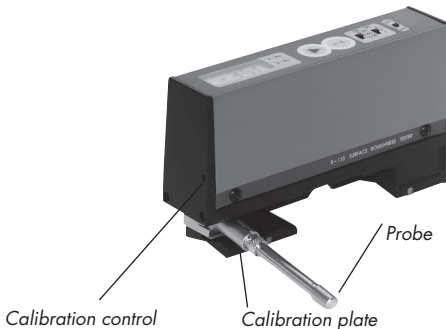

2. Press and release the start button, and take a reading from the center of the specimen. If the reading is within $\pm 0.1 \mu\text{m}$ of the value stated on the report of calibration certificate, calibration is within tolerance. If the reading differs from the value stated on the report of calibration certificate by more than $\pm 0.1 \mu\text{m}$, take additional readings around the central area of the specimen. If the reading still differ by more than the allowable tolerance, recalibrate the tester following the procedure below.
3. Using a screwdriver, carefully adjust the calibration control. Clockwise to increase the displayed Ra value, or Counter clockwise to decrease the displayed Ra value.
4. After adjusting the calibration control, remeasure the reference specimen to assure that the tester is within the calibration tolerance.

- When calibrating with a Small Bore Probe or Groove Bottom Probe, the probe should be in the 180° position. And make sure that the tester base is on the same height as the surface of the calibration specimen.

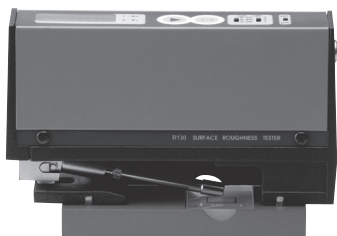

calibration plate or height stand

7. Operation

The tester will operate in any one of four probe positions. Selection of the proper probe position depends on the application.

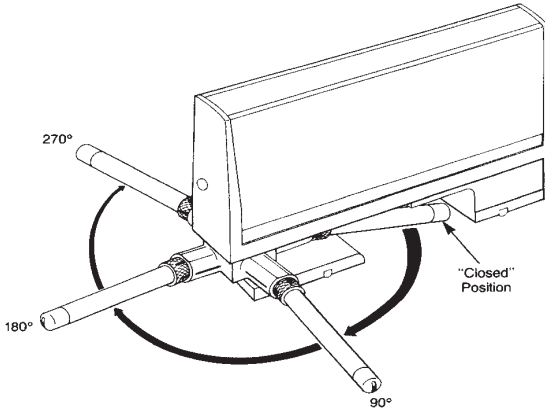

When changing probe positions, gently grasp the probe by its body; never handle the probe by its skid and stylus end. During the measuring cycle, the probe stylus and skid should be in contact with a surface, and the setup should be properly aligned. Otherwise, any readings obtained are not valid and are not to be used for measurement or tester performance evaluation purposes. The tester can be hand held or placed on a surface in any attitude, it will operate in virtually any position –horizontally, vertically, at any angle in between, even upside-down.

With the probe positioned on the workpiece surface to be measured, carefully adjust the tester and workpiece setup, so that the Reference Line (the upside of the Probe Mounting Block) is parallel to the bottom of the tester housing and parallel to the work-piece's surface (see below). This ensures that the probe skid and stylus are flush on the work surface, even though the probe body will be at an angle to the work surface.

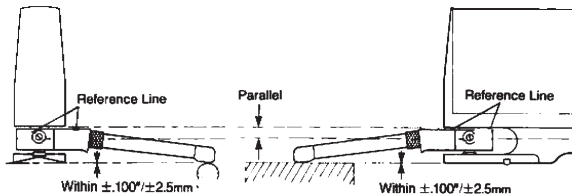

8. Probes

8.1 General purpose probe (R130-2001 or R130-2002)

For most surface roughness applications. R130-2001 has a 90° conical diamond stylus, .0004"/10µm radius per ISO specifications. R130-2002 has a 90° conical diamond stylus, .0002"/5µm radius per DIN standards.

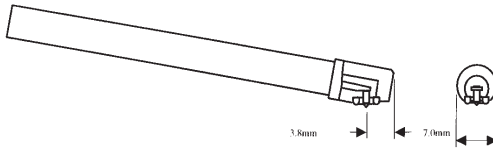

8.2 Transverse chisel probe (R130-2003)

For gaging sharp edges or small O.D.'s where probe is aligned with (in 180° or closed position) to axis of traverse. 90° diamond chisel stylus, .0004"/10µm radius.

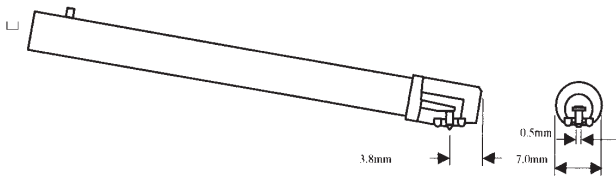

8.3 Parallel chisel probe (R130-2004)

For gaging sharp edges or small O.D. 's where probe is perpendicular (in 90° or 270° position) to axis of traverse. 90° diamond chisel stylus, .0004"/10µm radius.

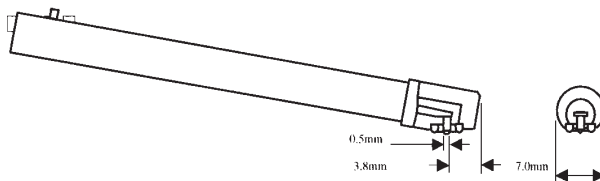

8.4 Small bore probe (R130-2005 or R130-2006)

For measuring small bores (min. inside diameter of 5.0mm, up to a depth of 15.0mm). 90° conical diamond stylus, .0004"/10µm radius for R130-2005; .0002/5µm radius for R130-2006.

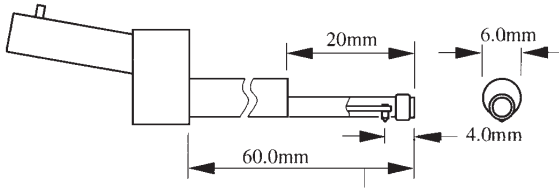

8.5 Groove bottom probe (R130-2007)

For measuring the bottoms of "O" ring grooves, recesses and holes to depth of 6.0mm. Also used for short lands and shoulders. 90° conical diamond stylus, .0004"/10µm radius.

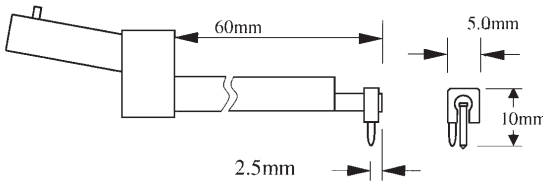

9. Probe replacement

1. Turn the tester upside down and swivel the Probe to its 90° position.
2. Loosen the knurled locking collar by turning it counter-clockwise approximately 3 turns, until the access slot is aligned with the probe pin slot in the probe mounting block. Grasp the probe by its body section, carefully withdraw the probe from its mounting block and the knurled locking collar. **Do not grasp the probe by its skid and stylus end. Do not remove the knurled locking collar from the probe mounting block, loosen it only enough to slide the probe out easily.**
3. Reverse the procedure to install a probe, aligning the pin on the bottom of the probe body with the access slot in the locking collar. **Make sure that the probe is fully inserted into the probe mounting block (so that the electrical connector is completely engaged) before tightening the locking collar. Finger tighten only.**
4. Check the tester's calibration after changing probes.

10. Analog signals output

The tester digital signals output feature permits measurement results to be transmitted to an external device such as a printer, computer or data collection system.

For further information concerning the signals output, please contact the supplier.

Printer settings

TA-220 settings 1 + 3 + 5 = on

TA-230 settings 2 + 3 + 6 + 7 = on



11. Maintenance

11.1 Protection & storage

To protect the tester when not in use, always return the probe to its closed position and replace the protective cover on the tester unit. Also, when not in use, always keep the tester and its accessories in the fitted case.

11.2 Cleaning

To clean the tester unit, use a soft, lint-free cloth moistened with a mild, non-abrasive, liquid or foam cleaning agent. Using a magnifier, periodically inspect the probe skid and stylus area for dust, dirt or other contamination. To clean the probe skid and stylus, use a soft (camel's hair), artist's brush moistened with denatured alcohol.

11.3 Repairs

When finding any trouble in using the tester, contact the suppliers. Do not disassemble the unit or attempt any further remedies.

12. Accessory: height stand

The height stand is intended to be used on a surface plate or other suitably flat surface to measure workpiece surfaces ranging in height from flush with the work surface to a maximum height of approximately 175mm. The tester probe can be in either its 90° or 180° position.

1. Mount the tester in the bracket on the height stand using the captive screw in the base of the bracket. The screw mates with the tapped hole in the bottom of the tester housing. Tighten the screw by finger.
2. Position the height Stand so that the probe is above the workpiece surface to be measured. Use the coarse height adjustment to bring the probe skid and stylus barely in contact with the surface. Use the fine adjustment to make the reference line (the upside of the mounting block) parallel to the bottom of the tester housing.
3. Once the setup is correctly adjusted, and the probe is properly positioned on the workpiece surface, gently press and release the start button on the tester to make the measurement.

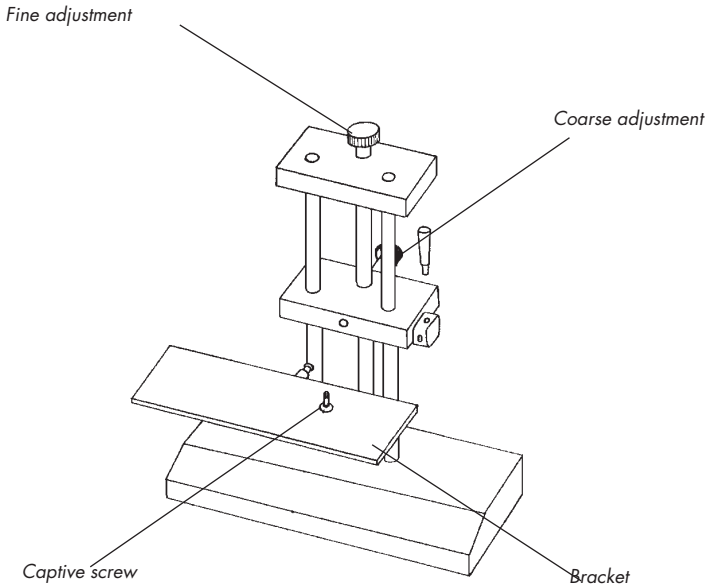

EC-Declaration of Conformity

This certifies that the following designated product
R130/R135 (Portable roughness tester)
complies with the essential protection requirements of
Council Directive 89/336/EEG approximation of the laws of the
Member States relating to electromagnetic compatibility.

This declaration applies to all specimens manufactured
in accordance with the manufacturing drawings
which form part of this declaration.

Assessment of compliance of the product with the requirements relating
to the compatibility was based on the following standards:
EN55022, EN60555-2, EN60555-3, EN50082-1

This declaration is the responsibility of the manufacturer/importer:

Company name:	INNOVATEST Europe BV
Address:	Borgharenweg 140
Telephone / Telefax:	+31-43-3520060 / +31-43-3631168
Name of the subscriber:	Nicole Paulissen-Schiffer
Position:	General Manager

Maastricht



City

Authorised representative signature

IN09-115 060715

CORPORATE HEAD OFFICE

INNOVATEST Europe BV
MANUFACTURING, DISTRIBUTION & SERVICE
Borgharenweg 140
6222 AA Maastricht (The Netherlands)
Phone: +31 43 3520060
Fax: +31 43 3631168
E-mail: info@innovatest-europe.com
Website: www.innovatest-europe.com